



Company Name: _____ Date Submitted: _____

Project Name: _____ Date Approved: _____

Email: _____ Quote #: _____ SO #: _____ Revision

PRE-PLUMB SELECTION GUIDE

CONFIGURATION 1

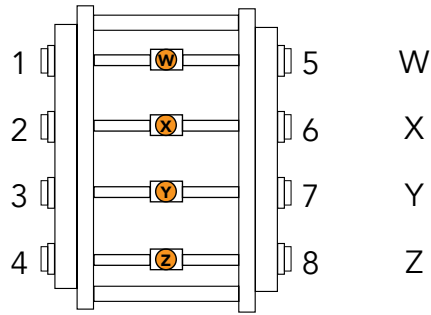

Dispenser Model: _____

Quantity: _____

CONFIGURATION 2

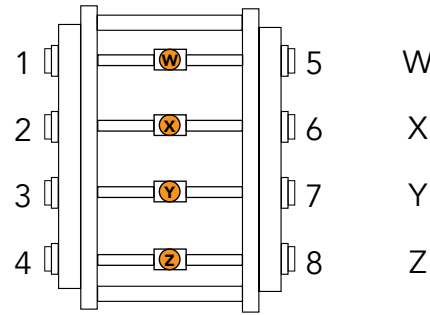

Dispenser Model: _____

Quantity: _____

CONFIGURATION 3

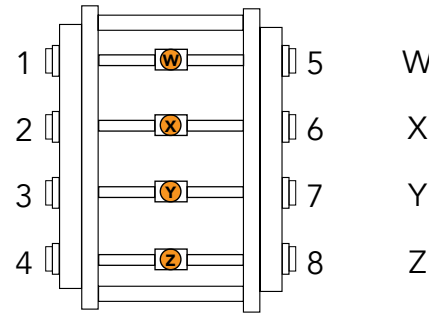

Dispenser Model: _____

Quantity: _____

CONFIGURATION 4

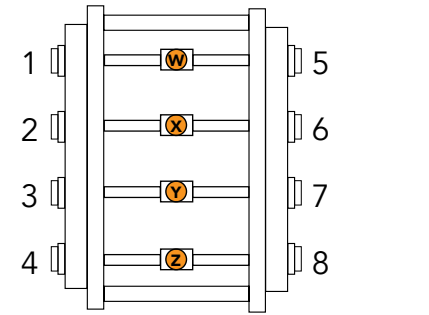

Dispenser Model: _____

Quantity: _____

CONFIGURATION 5

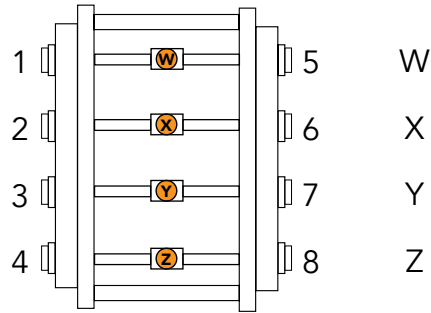

Dispenser Model: _____

Quantity: _____

CONFIGURATION 6

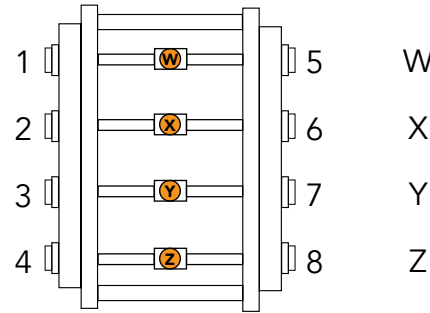

Dispenser Model: _____

Quantity: _____

CONFIGURATION 7

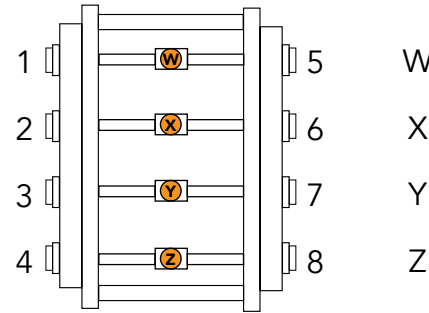

Dispenser Model: _____

Quantity: _____

CONFIGURATION 8

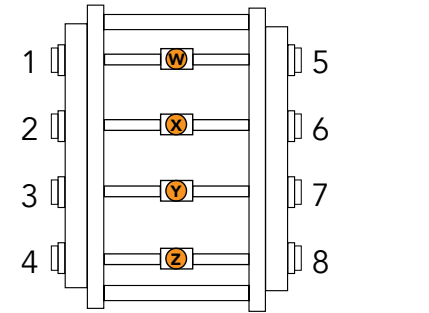

Dispenser Model: _____

Quantity: _____

SVA MATERIAL

- Powder Coated
- Stainless Steel

FRAME MATERIAL

- Galvanized
- Stainless Steel

PENETRATION FITTING

- PCI
- NOV
- OPW

SHEAR VALVE

OPW

- 1-1/2" SP Female
- 1-1/2" DP Female
- 10+ 1-1/2" Female
- 2" SP Female
- 2" DP Female
- 10+ 2" DP Female

EMCO

- 1-1/2" DP Female-SS

FLEX CONNECTOR

- 12" MxMQF
- 15" MxMQF
- 18" MxMQF

NOTES

PIPING

- RTIIA
- Stainless Steel
- Poly
- Fusion

DISPENSER SUMP

- RSC
- DCL
- DP



CONFIGURATION 1

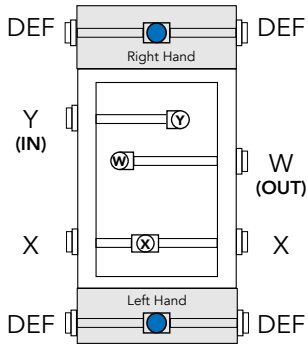

POSITION X

- Penetration Fitting**
 PCI NOV OPW
- Primary Pipe Size**
 2" 3"
- Shear Valve**
 2" OPW SP Female
 2" OPW DP Female
 2" EMCO DP SS Female

- Flex Connector**
 2.0" x 12" MxMQF

POSITION W, Y, DEF

- Penetration Fitting**
 PCI NOV OPW
- Primary Pipe Size**
 2"
- Shear Valve**
 1.5" OPW SP Female
 1.5" OPW DP Female*
 1.5" EMCO DP SS Female*

- Flex Connector**
 1.5" x 12" MXMQF
 1.5" x 15" MXMQF
 1.5" x 18" MXMQF

Dispenser Model: _____

W/ DEF Containment? Yes No

Qty: _____

CONFIGURATION 3

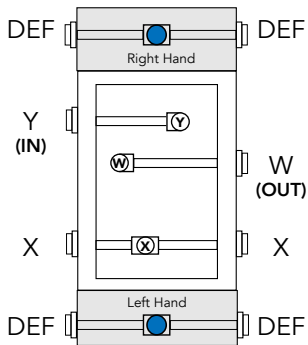

POSITION X

- Penetration Fitting**
 PCI NOV OPW
- Primary Pipe Size**
 2" 3"
- Shear Valve**
 2" OPW SP Female
 2" OPW DP Female
 2" EMCO DP SS Female

- Flex Connector**
 2.0" x 12" MxMQF

POSITION W, Y, DEF

- Penetration Fitting**
 PCI NOV OPW
- Primary Pipe Size**
 2"
- Shear Valve**
 1.5" OPW SP Female
 1.5" OPW DP Female*
 1.5" EMCO DP SS Female*

- Flex Connector**
 1.5" x 12" MXMQF
 1.5" x 15" MXMQF
 1.5" x 18" MXMQF

Dispenser Model: _____

W/ DEF Containment? Yes No

Qty: _____

NOTES

CONFIGURATION 2

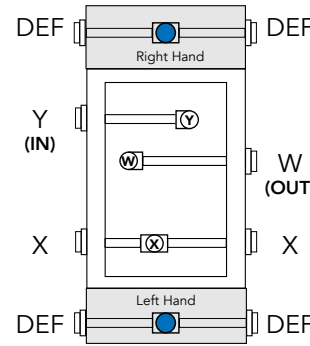

POSITION X

- Penetration Fitting**
 PCI NOV OPW
- Primary Pipe Size**
 2" 3"
- Shear Valve**
 2" OPW SP Female
 2" OPW DP Female
 2" EMCO DP SS Female

- Flex Connector**
 2.0" x 12" MxMQF

POSITION W, Y, DEF

- Penetration Fitting**
 PCI NOV OPW
- Primary Pipe Size**
 2"
- Shear Valve**
 1.5" OPW SP Female
 1.5" OPW DP Female*
 1.5" EMCO DP SS Female*

- Flex Connector**
 1.5" x 12" MXMQF
 1.5" x 15" MXMQF
 1.5" x 18" MXMQF

Dispenser Model: _____

W/ DEF Containment? Yes No

Qty: _____

CONFIGURATION 4

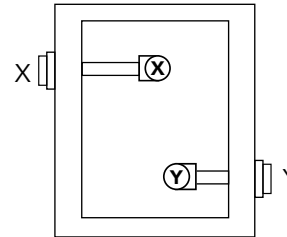

POSITIONS X, Y

- Penetration Fitting**
 PCI NOV OPW
- Primary Pipe Size**
 2"
- Shear Valve**
 1.5" OPW SP Female
 1.5" OPW DP Female
 1.5" EMCO DP SS Female

- Flex Connector**
 1.5" x 12" MXMQF
 1.5" x 15" MXMQF
 1.5" x 18" MXMQF

Dispenser Model: _____

Qty: _____

**Pre-Plumb Dispenser Sumps are Non-Returnable and Non-Refundable*

Signature: _____

Date Approved: _____